

## Constant Velocity Particle Model Worksheet 1: Motion Maps and Position vs. Time Graphs

1. Given the following position vs. time graph, draw a motion map with one dot for each second.

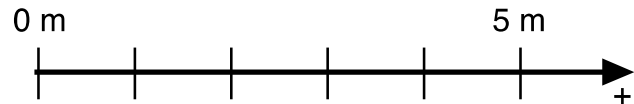
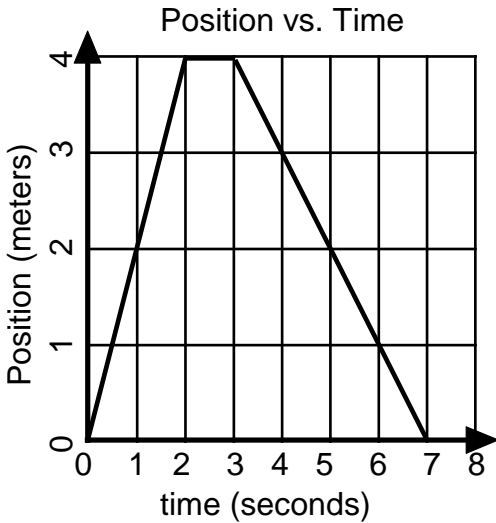

- a. Describe the motion of the object in words:
- b. Draw a motion map of the above position-time graph.

2. a) Given the following motion map, where positions have been recorded with one dot each second, draw a position vs. time graph.

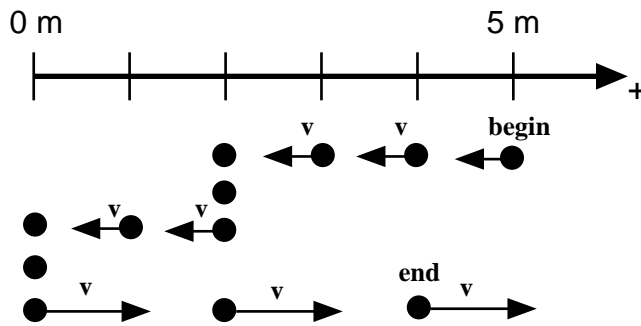

b) Describe the motion of the object in words:

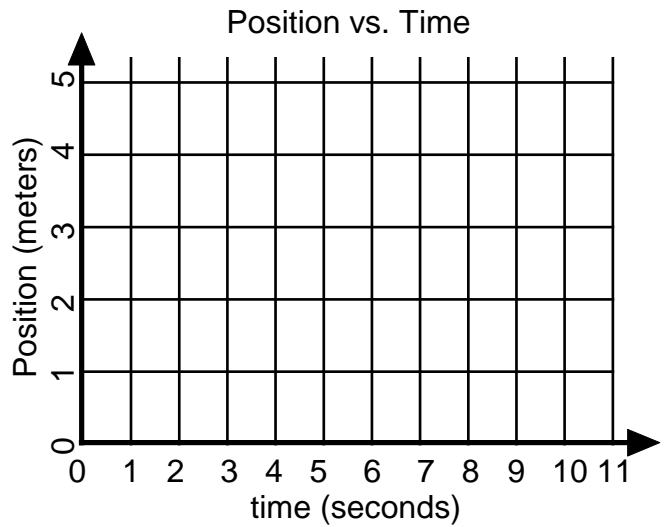

3. Consider the position vs. time graph below for cyclists A and B.

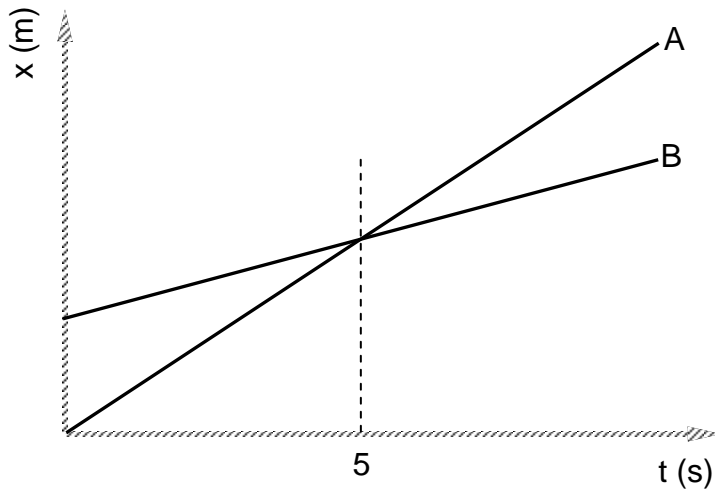

a. Do the cyclists start at the same point? How do you know? If not, which is ahead?

b. At  $t = 7$  s, which cyclist is ahead? How do you know?

c. Which cyclist is traveling faster at 3 s? How do you know?

d. Are their velocities equal at any time? How do you know?

e. What is happening at the intersection of lines A and B?

f. Draw a motion map for cyclists A and B.

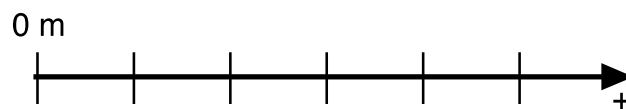

4. Consider the new position vs. time graph below for cyclists A and B.

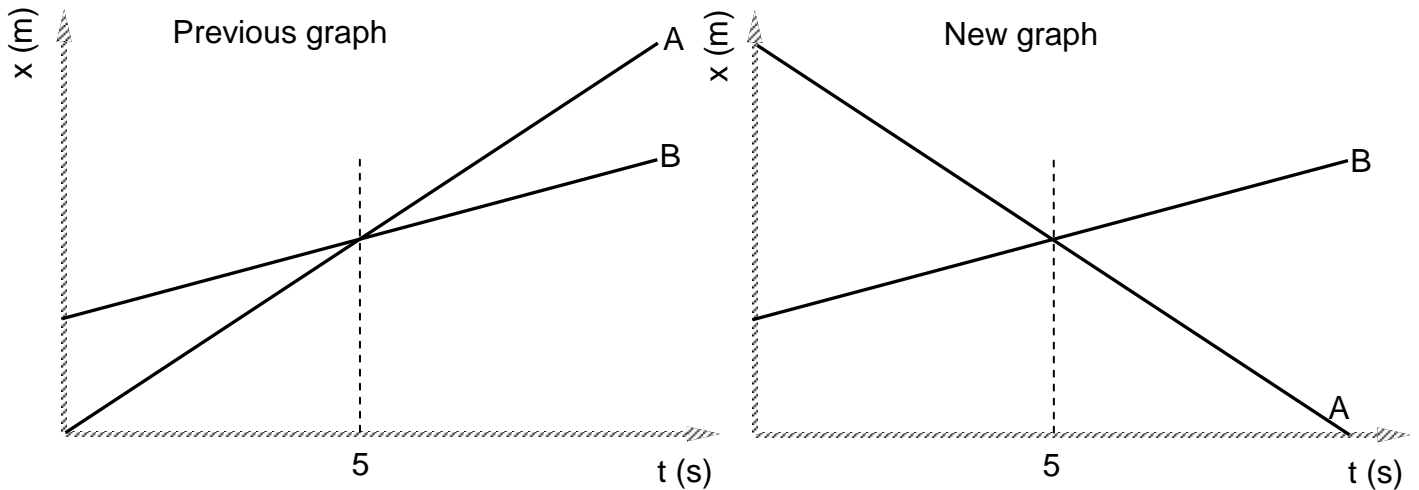

a. How does the motion of the cyclist A in this graph compare to that of A in question 3?

b. How does the motion of cyclist B in this graph compare to that of B in question 3?

c. Which cyclist has the greater speed? How do you know?

d. Describe what is happening at the intersection of lines A and B.

e. Which cyclist has traveled further during the first 5 seconds? How do you know?

f. Draw a motion map for cyclists A and B.

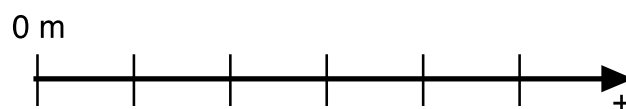

5. An overhead snapshot of Dorothy and Toto walking along the yellow brick road is shown below.

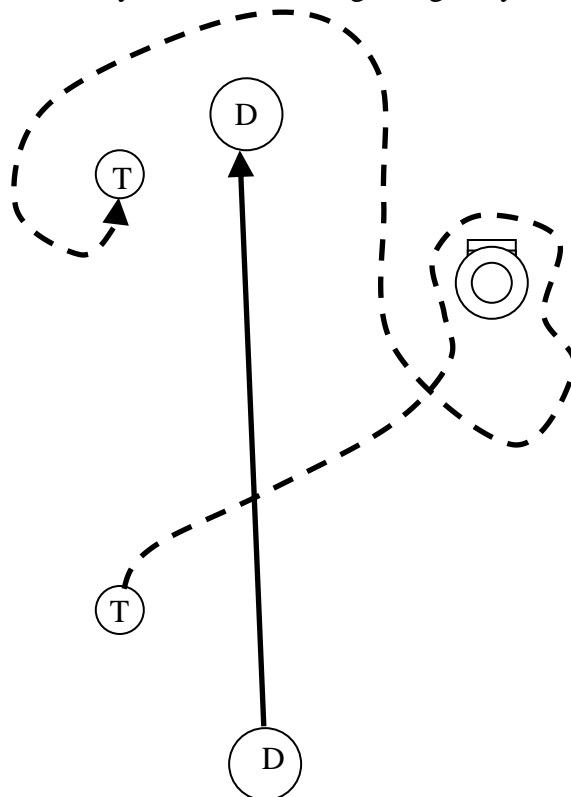

a. From start to finish, who travels farther? Justify your answer.

b. Develop two different definitions for measuring “how far” something travels.